

Type of Project:	Shelter Housing Durable Solution	Country:	Serbia
Approach:	Self Help	Realisation Year:	2001-2003
Project name:	Self Help Construction Type “F”	Version:	1
		Date:	June 2003



Initial Situation, Context

As a consequence of the war conflicts in Croatia and Bosnia 1991-95 and Kosovo 1999, Serbia hosts some 452.000 refugees and 180.000 IDPs. A majority of them (65%) expressed their wish to integrate in Serbia. To support the local integration process, UNHCR started in 1997 the Local Settlement Program (LSP) and the construction of settlements for refugees in Serbia.

Since early 1999 LSP has focused on self-help construction. The framework for this is an integral part of the National Strategy. This has led to high levels of integration as the refugees, who already enjoyed full access to education, health facilities and citizenship as well as working permits, were able to build their own accommodation. Moreover, one member of each beneficiary family was provided a job by the municipality.

Goals, Beneficiaries

In order to support the Government in its endeavours to assist the refugees in their integration, UNHCR and SDC participate in the construction of new housing units in selected municipalities. Beneficiaries are refugee families of medium to big size (4-6 family members), able to contribute the construction with their working force and initiative. Application for FRY citizenship is the precondition. Ratio between refugees residing in CCs (Collective Centres) and in private accommodation differed from year to year – from 40:60 in 2001 in favour of private accommodation, 50:50 in 2002, up to 70:30 in 2003 in favour of CCs residents.

Approach

The program is promoting a socio-economic integration, especially by a self-reliance generating component with a job being provided by the municipality. Beside this the community is also committed by providing the necessary land plots and infrastructure (supply of access, electric and water)

House type F is a semi-detached house for two families, with the possibility of further extensions.

Technical details:

Self-help program started in early 1998. At the beginning of 2001, type F was developed as a result of the input received from the beneficiaries and the acquired experience.

The standard of the houses is in line with the prevailing local standards. The technical solutions are sustainable in each particular self-help project. Local material is used according to the local building practice.

Within the first phase material is provided by UNHCR/SDC for completion of an apartment of 34 m2 for each family. Future extensions (phases II and III) are already included in the building permit, providing later on a total living area of 107 m2. Such extensions are to be financed and constructed by the beneficiaries themselves.

Partner(s)

- SCR (Serbian Commissioner for Refugees): to provide building lots, given by the municipality, of approx 700 m² of land per house (2 families), endorse main project design and technical documentation, as well as to obtain the building permits for the buildings and infrastructure
- UHNCR: to provide funds for the purchase of building materials and tools for refugee self-help construction
- Municipality: to provide primary and secondary infrastructure for the settlement and to provide agricultural land under humanitarian rent or employment to one member of each family
- SDC: to develop the technical concept, participate in financing with its overhead cost, and assist the refugees in the construction by purchasing and delivering building material and by technical guidance and co-ordination during construction process.

Implementations/Results

Selection of Beneficiaries is done by the Commission (consisting of contracting parties' representatives) according to previously defined criteria.

The building material, stored at the local storage, is given out in phases.

The beneficiaries form teams, which are assisted by SDC architects and field monitors, as well as by local supervisors.

So far 794 units have been built with self-help approach.

Cost, Financing

Cost per unit is approx 7'000 _/unit, for the building material and tools, not including the overhead costs, assistance, and co-ordination of SDC. Tools and building materials have been funded by UNHCR/SDC/FOR.

Problems/Constraints

- The problem of the ownership is still formally not defined by the legislation.
- It is very difficult for some municipalities to comply with their obligation to provide employment for a family member and to offer a land plot.
- Due to the lack of funds, some municipalities have difficulties in providing infrastructure.
- This category of beneficiaries is not the most vulnerable.

Lessons learned What was useful in the approach?

- The beneficiaries take an active part in construction of their house, giving them the ownership rights and facilitating the integration.
- This type of house can be extended later on according to the needs of each family.
- This approach reduces the investment per family considerably.

Lessons learned What should be done different next time?

- The ownership issue should be settled.
- Involving the most vulnerable refugees should be considered. (A possible solution has already been done within one pilot project)

Preconditions and Limitations for this approach

- Political acceptance of this proposal by national and local authorities
- Close cooperation with other partners in identification of municipalities and beneficiaries
- Financial capacity of other partners to participate in the program
- Construction office with administrative and technical capacity to implement this type of project

Evaluations SDC/UNHCR evaluation August 2002**For further information**

Recommended Contacts:	E. Morosin, SDC Housing Office Belgrade e-mail: sdc.ho@eunet.yu
Recommended Institutions:	SDC/HA, desk Europe +CIS
Recommended books/reports:	SDC/HA Fact Sheet June 2002: "The Swiss Contribution"
Relevant other projects (links):	similar SDC/HA Projects in Kosovo, Croatia and Bosnia

Annex: (technical drawings, schemata) see page 3-5

House Type “F”

Initial starting phase (phase I) and later extensions (phases II and III)

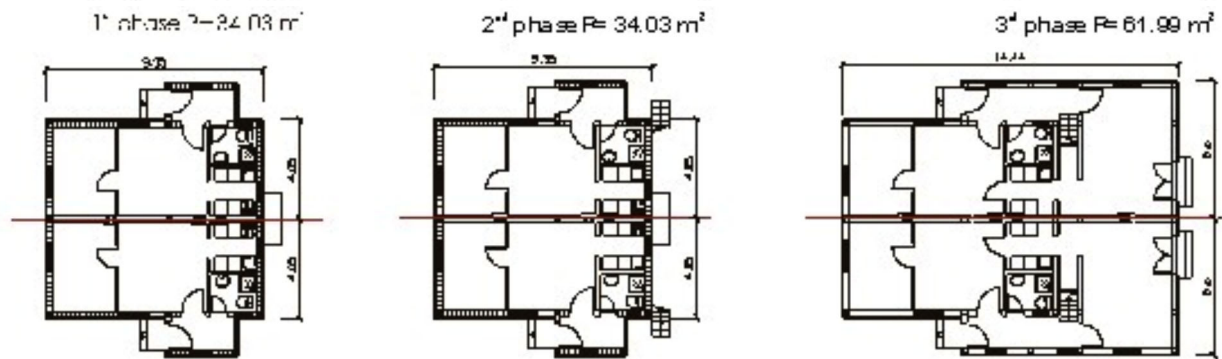
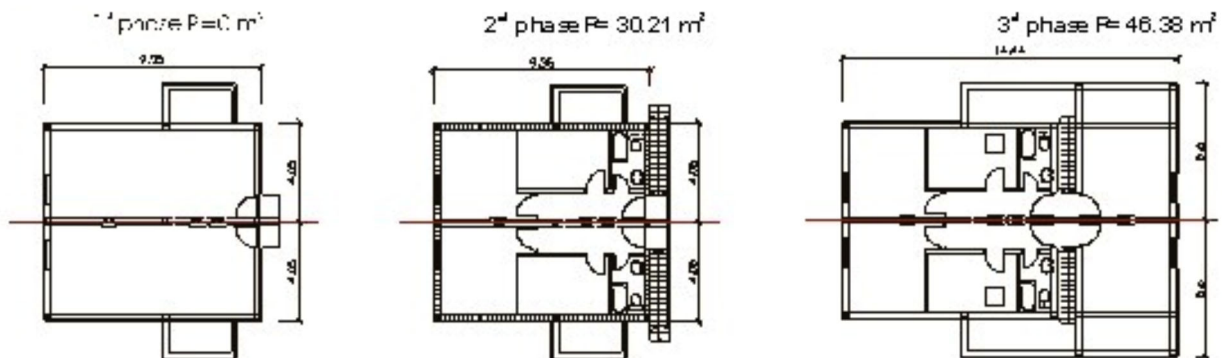
FLOOR PLAN**ATTIC****SIDE FACADE**

Type of Project:	Shelter Housing Durable Solution	Country:	Serbia
Approach:	Self Help	Realisation Year:	2001 - 2003
Project name:	Self Help Construction Type "F"	Version:	2
		Date:	February 2004

Procedures Checklist

General Information

The Self Help project is part of the "UNHCR Local Settlement Programme", running from 1998 until end of 2003. The refugees are given complete construction material and are obliged to finish the construction of their house within 12 months. The house is to be built on the land transferred from the Municipality to the Serbian Commissioner for Refugees (SCR), which will be the owner of the house. As soon as citizenship is obtained and the infrastructure cost are paid to the Municipality, the refugees may request to become owner of the house. SCR is monitoring the use of the finalized units.

Goals, Beneficiaries

Self-relying refugee families with 4-6 family members, which are able to build themselves.

PROJECT IDENTIFICATION

1. Problem Detecting: SCR/UNHCR Initiative

- Is there an awareness of the high number of potential beneficiaries having opted to integrate in Serbia?
- Is the need of solving the housing problem for those people based on a national/regional strategy?
- Is the closing of Collective Centres a priority of the Government?
- How are the specific situations in the involved Municipalities?

2. Concept: SCR/UNHCR Initiative

- Analyse the needs for integration of the beneficiaries
- Analyse the living standards of the local population
- Define the concept and participation of each partner
- Find a consensus about the concept
- Prepare a presentation/documentation of already implemented projects (if existing)

3. Architectural Solution: SDC/UNHCR Initiative

- Is there a need to improve the design of existing solutions?
- Analyse the past experiences (other types of houses)
- Analyse the housing needs of integrated families
- Propose the layout plan and the preliminary design of the house

4. Identification of Locations: SDC Initiative + SRC + Municipality + UNHCR

- Check the willingness of the Municipality to participate in the project
- Analyse the municipal potential to participate in the project
- Motivate, if needed, the Municipality to find potentials and resources
- Check technically the appropriateness of the offered land

PROJECT STRUCTURE

5. Partnership: SDC Initiative + SRC + Municipality + UNHCR

- Find a consensus about the accepted locations
- Prepare first draft of Agreement based on preliminary discussion about responsibilities.
- Define and sign the final Agreement and the Criteria's for selection of the beneficiaries

6. Responsibility (Agreement): All Partners

- a **SDC**: Identification of land, technical documents, selection of the beneficiaries, implementation
- b **SCR**: Identification of land, transferring of the land, selection of the beneficiaries, monitoring the transfer of property to the beneficiaries
- c **UNHCR**: Identification of land, funding the construction materials for houses and septic tanks, furnishing of the houses. (implemented by SDC)
- f **Municipality**: Provides land and infrastructure, provides all permits and authorizations, and performs day-to-day supervision of the construction. Provides electricians for electrical works and storage place for the construction materials. Provides employment or land in humanitarian lease for one member of the family.

PROJECT IMPLEMENTATION**7. Selection of beneficiaries: SDC + SCR + UNHCR + Municipality**

- a Set up the Joint Commission: SDC/SCR/UNHCR/Municipality
- b Define the criteria's for advertising the project (Municipality) and for applying (Beneficiaries).
- c Preliminary selection of the beneficiaries by the joint commission
- d Interview the candidates by the Commission
- e Final selections
- f Signing of the contracts with beneficiaries

8. Building works: SDC + SCR + UNHCR + Municipality

- a Find urban planning conditions for the project
- b Organise urban planning permit
- c Elaborate the main and executing design and documents, Provide technical check-up
- d Organise approval from the relevant organizations
- e Organise the necessary "Building Permit"
- f Sign the Agreements (all). Final selection of beneficiaries (all). Sign the agreements with beneficiaries (SDC-Ben.) Sign the agreement of cooperation (SDC-Mun.)
- g Organise Tendering (supply of building material)
- h Organise Contracting, Order of the construction material
- i Open the construction site
- j Run the project monitoring
- k Find and organise the project acceptance
- l Organise the final account
- m Organise the documents for "Permit for use" and handover

Legend

MUN: Municipality

BEN: Selected Refugee Families

SCR: Serbian Commissioner for Refugees

For further information

Recommended Contacts:	E. Morosin, SDC Housing Office Belgrade e-mail: sdc.ho@eunet.yu
Recommended Institutions:	SDC/HA, desk Europe + CIS
Recommended books/reports:	SDC/HA Fact Sheet June 2002: "The Swiss Contribution"
Relevant other projects (links):	similar Projects are planned in 2003/4 in Kosovo